

REVISIONS				
P.	LTN	DESCRIPTION	DATE	APVD
A8		REVISED PER ECO-15-003872	25MAR2015	DD DS
A9		REVISED PER ECO-16-003526	09MAR2016	JM DS

- 1 ACCEPTS #3 SELF TAPPING THREAD FORMING SCREWS OR METRIC EQUIVALENT. DRIVE TO 0.6-0.8 N-m
- 2 DATE CODE IN THIS LOCATION USING 5 DIGIT CODE
FIRST 2 DIGITS = YEAR, SECOND 2 DIGITS = WEEK
LAST DIGIT = DAY.
- 3 MATERIALS: HEADER HOUSING - GLASS FILLED PBT
PINS - TIN OR GOLD PLATED BRASS
- 4 HOUSING COLORS ARE MECHANICALLY KEYED TO MATE ONLY WITH IDENTICALLY COLORED PLUG ASSEMBLIES.
- 5. HEADER MATES TO PLUG ASSEMBLY 776164 WHICH USES REELED TERMINAL 770520 OR LOOSE PIECE TERMINAL 770854.

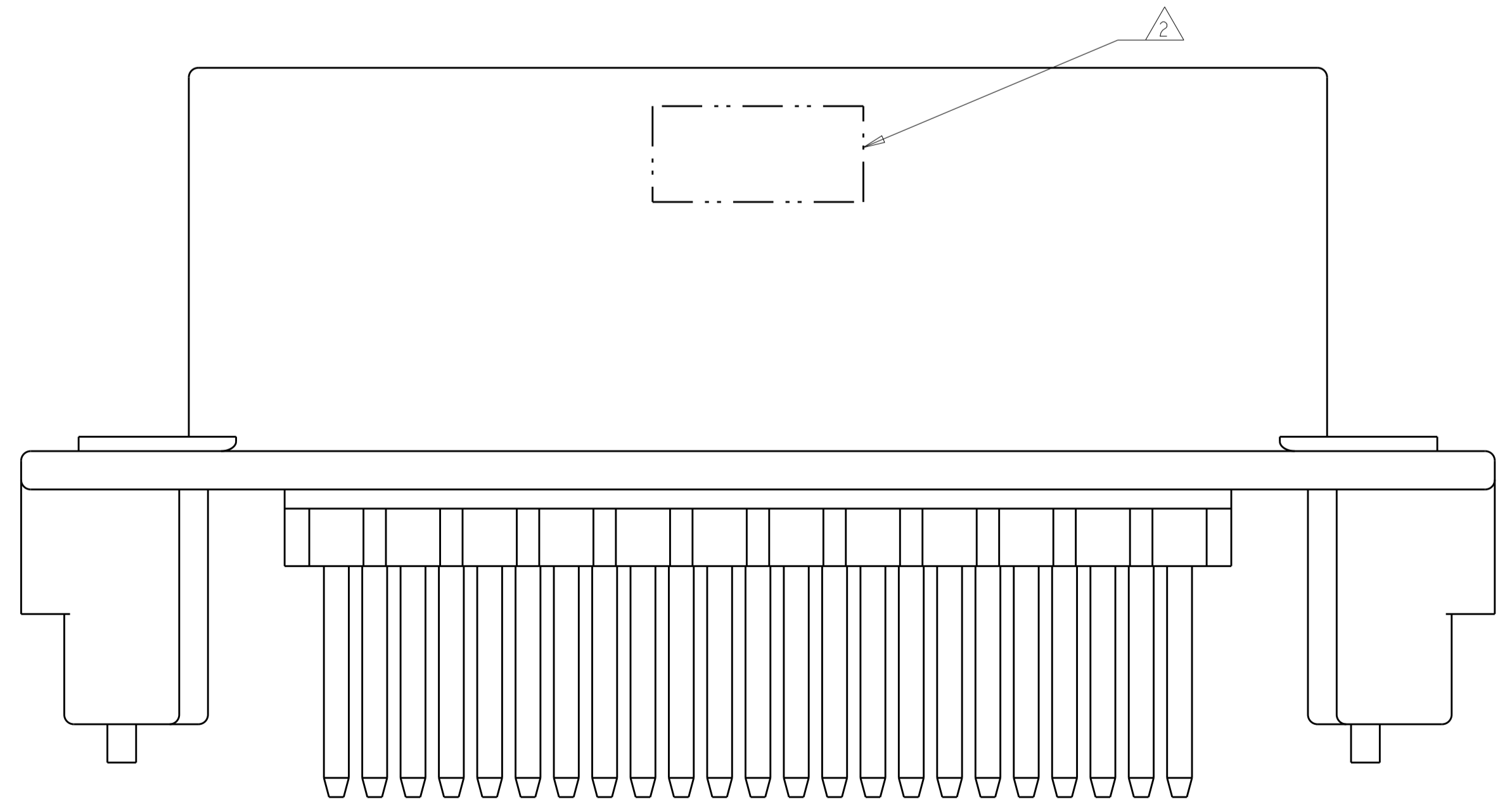
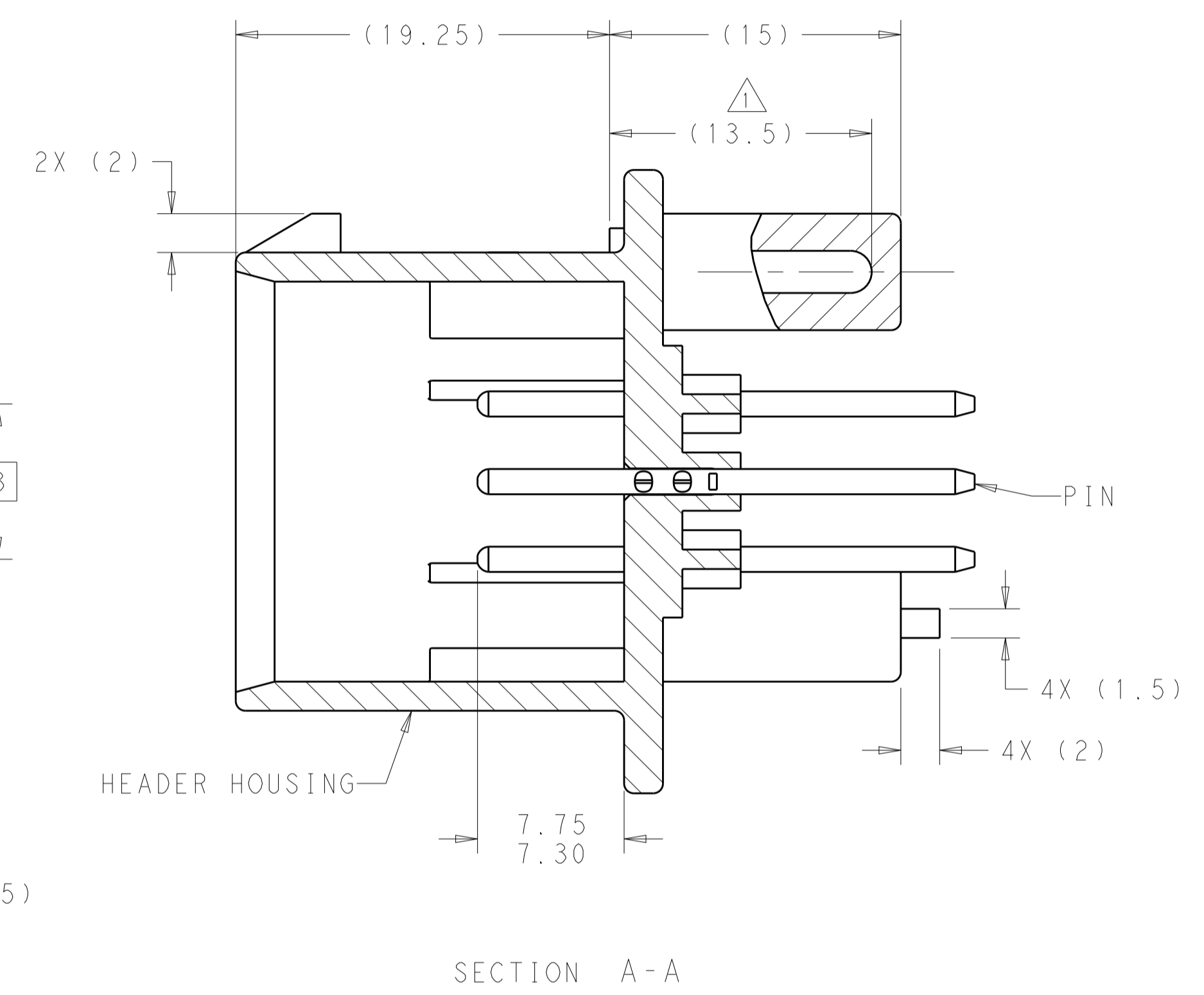
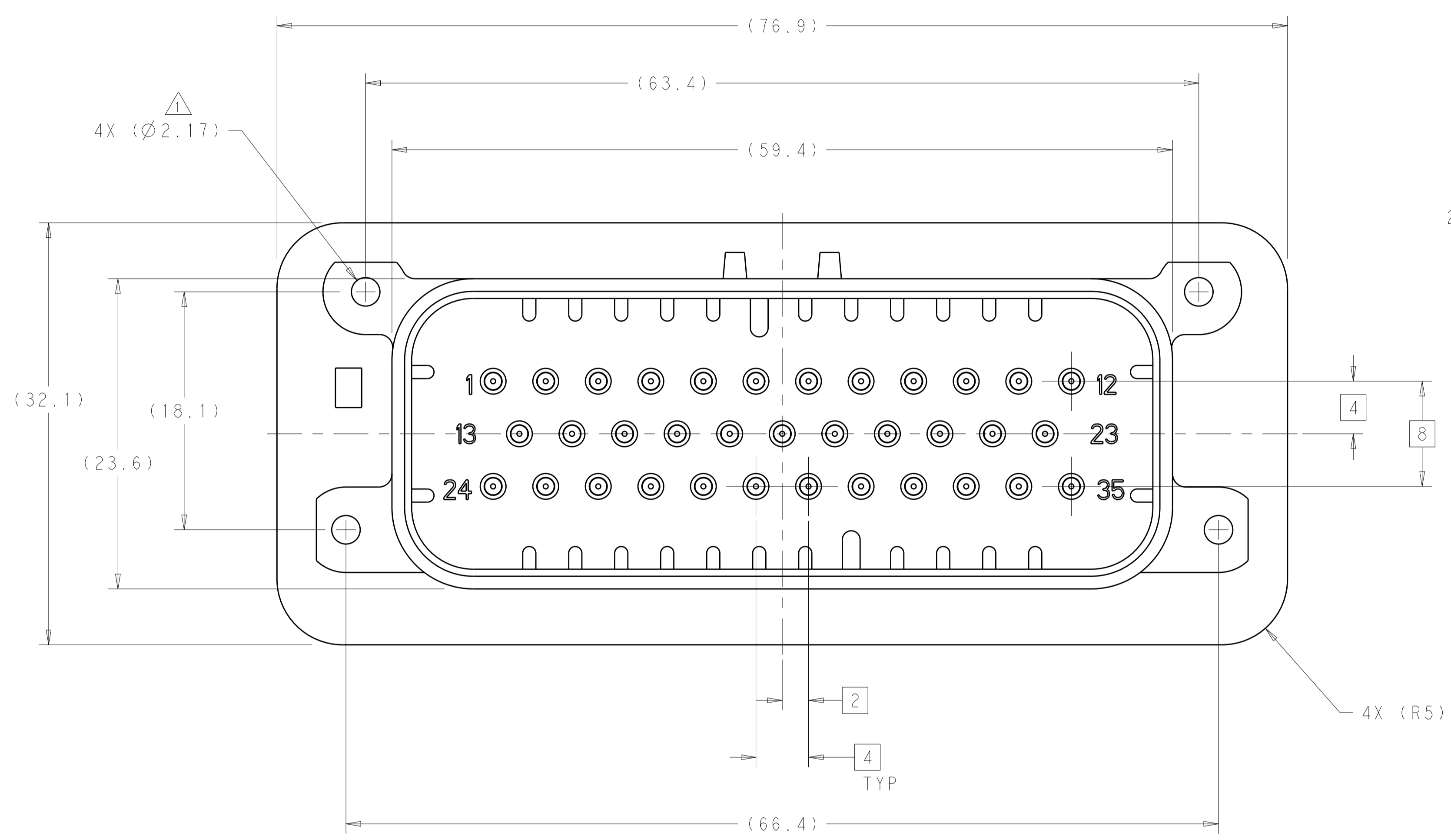

776230-1 & 1-776230-1 SHOWN

ORANGE	DURAGOLD	1-776230-6
BLUE	DURAGOLD	1-776230-5
GRAY	DURAGOLD	1-776230-4
NATURAL	DURAGOLD	1-776230-2
BLACK	DURAGOLD	1-776230-1
BLUE	TIN	776230-5
GRAY	TIN	776230-4
NATURAL	TIN	776230-2
BLACK	TIN	776230-1
HEADER COLOR	PLATING	PART NUMBER

THIS DRAWING IS A CONTROLLED DOCUMENT. DIMENSIONING AND TOLERANCING PER ASME Y14.5M-2009.		OWN: D. STRAUSSER 04FEB2010 CHK: D. STRAUSSER 22MAR2010 APVD: D. STRAUSSER 27APR2010	NAME: ASSEMBLY, HEADER, 35 POSITION, VERTICAL, AMPSEAL	
DIMENSIONS: mm	TOLERANCES UNLESS OTHERWISE SPECIFIED: 0 PLC ±0.2 1 PLC ±0.13 2 PLC ±0.13 3 PLC ±0.13 4 PLC ±0.13 ANGLES ±0.5°	PRODUCT SPEC: 108-1329 APPLICATION SPEC: 114-16016	SIZE: A1 CAGE CODE: 00779 DRAWING NO: 776230	RESTRICTED TO: -
MATERIAL: 3	FINISH: 4	WEIGHT: -	CUSTOMER DRAWING	SCALE: 4:1 SHEET 1 OF 2 REV: A9

REVISIONS				
P.	LTH	DESCRIPTION	DATE	APPV
-	-	SEE SHEET 1	-	-

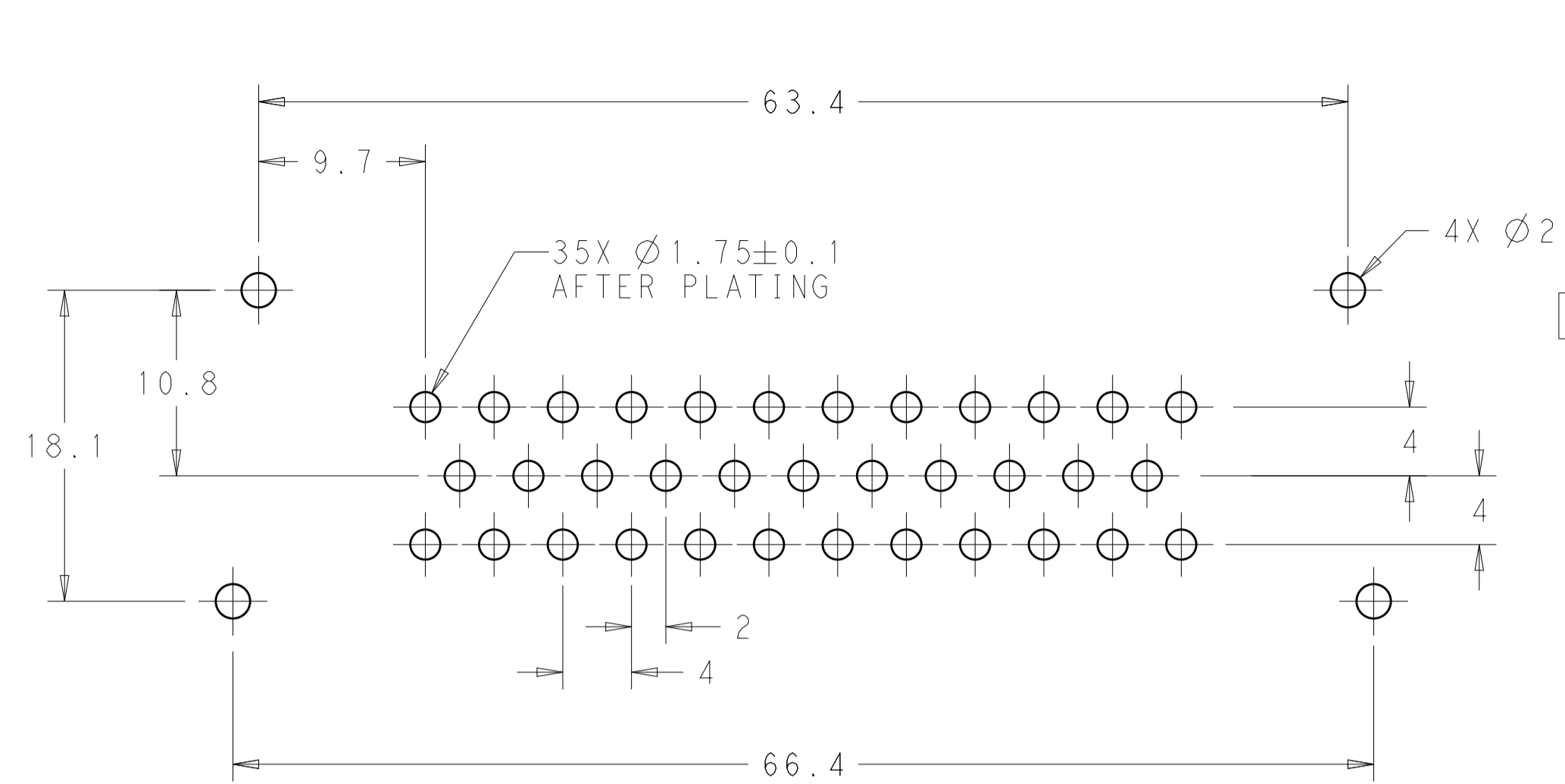

RECOMMENDED P.C. BOARD LAYOUT
 FOR 1.57 THICK P.C. BOARD

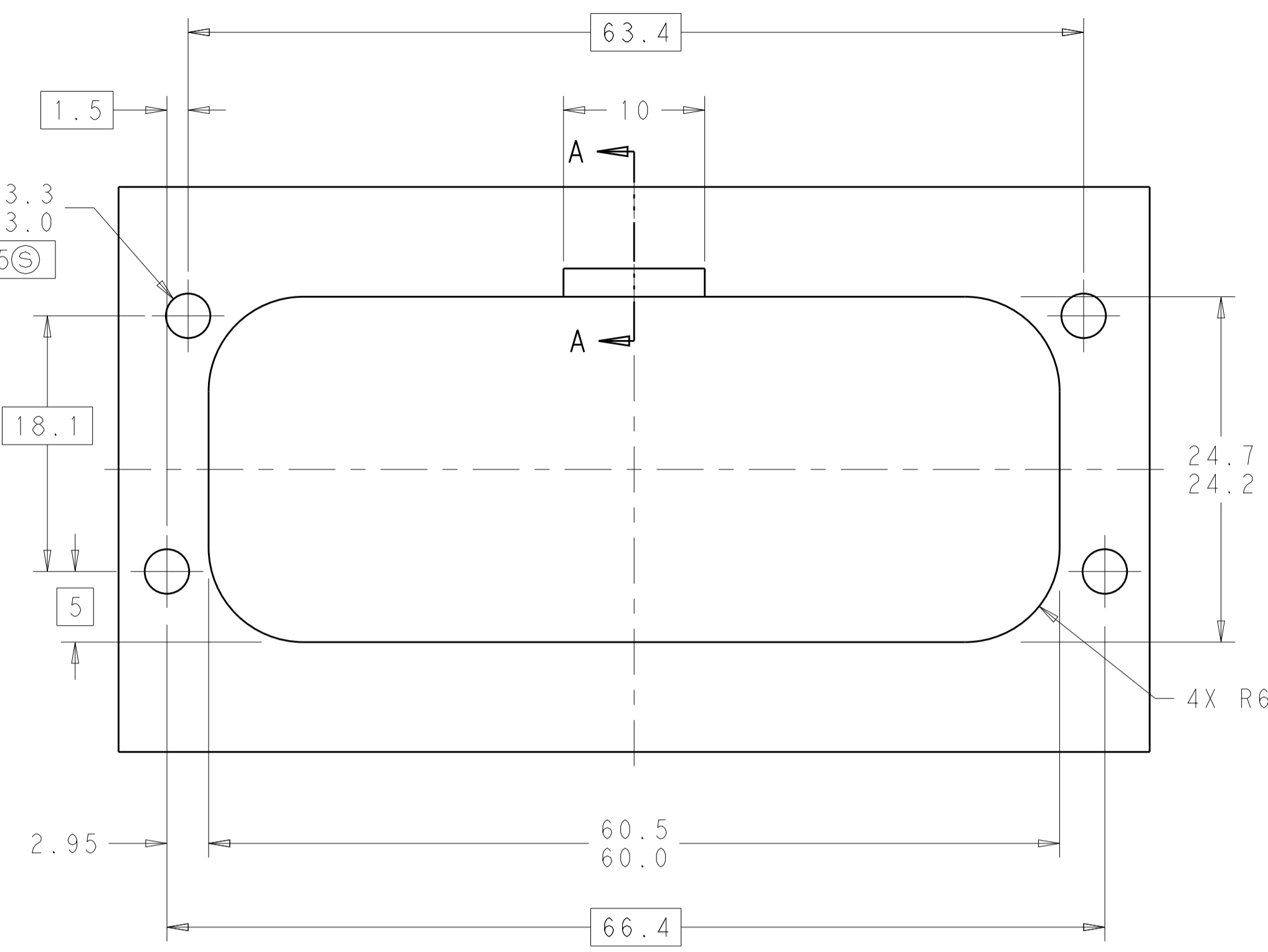

RECOMMENDED MOUNTING HOLE LAYOUT
 FOR 5.0 MAX THICK PANEL

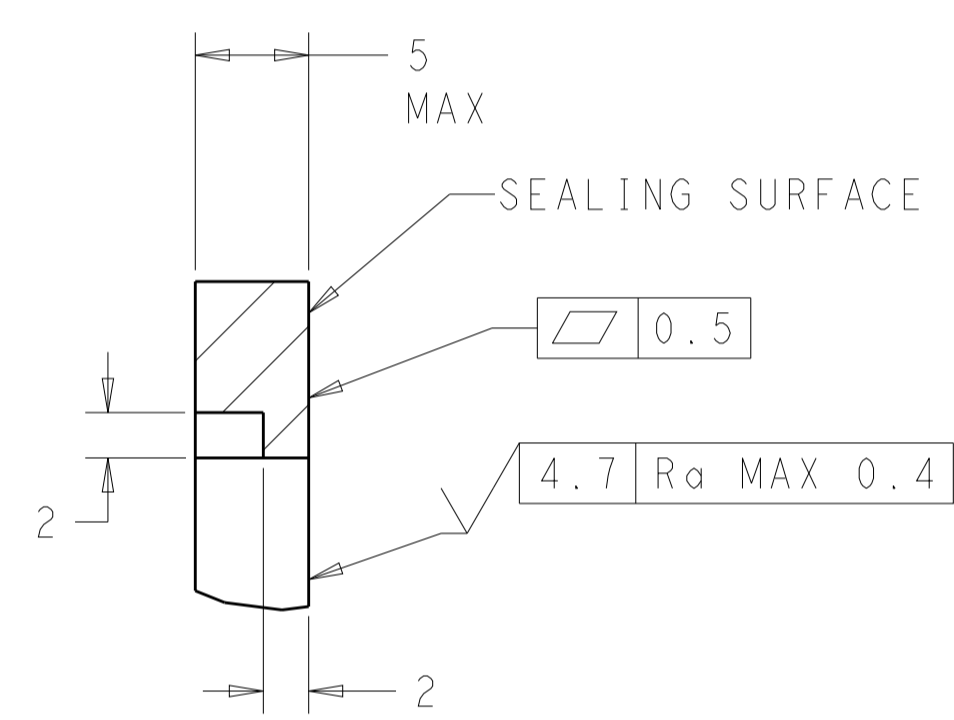

SECTION A-A
 OPTIONAL CONSTRUCTION IF PANEL
 THICKNESS IS GREATER THAN 2.0

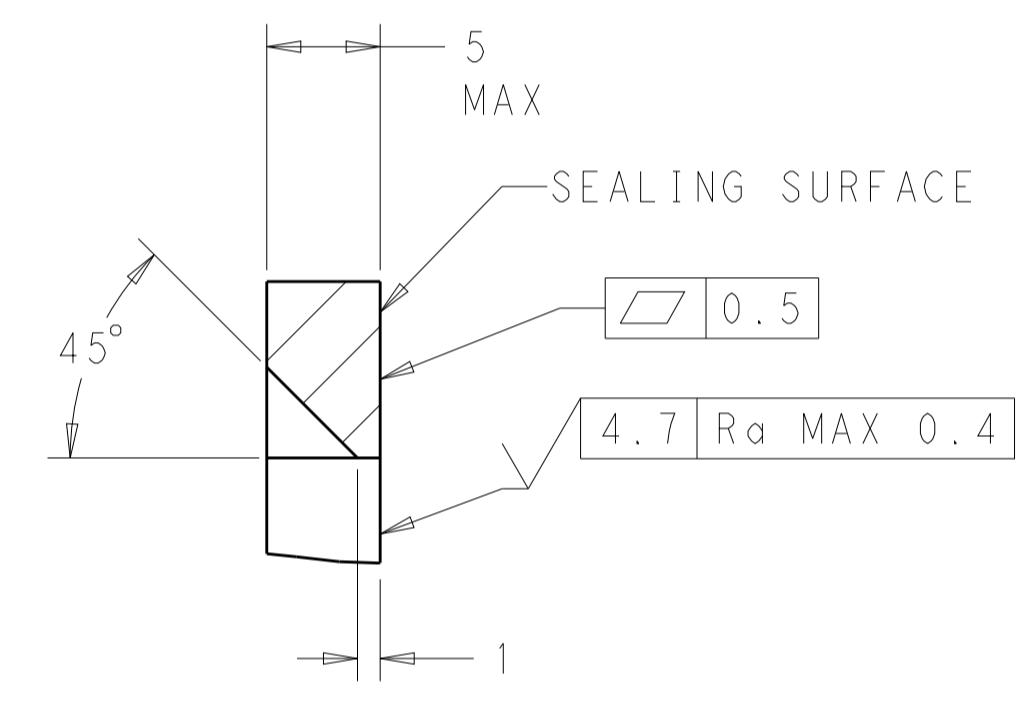

SECTION A-A
 OPTIONAL CONSTRUCTION IF PANEL
 THICKNESS IS GREATER THAN 2.0

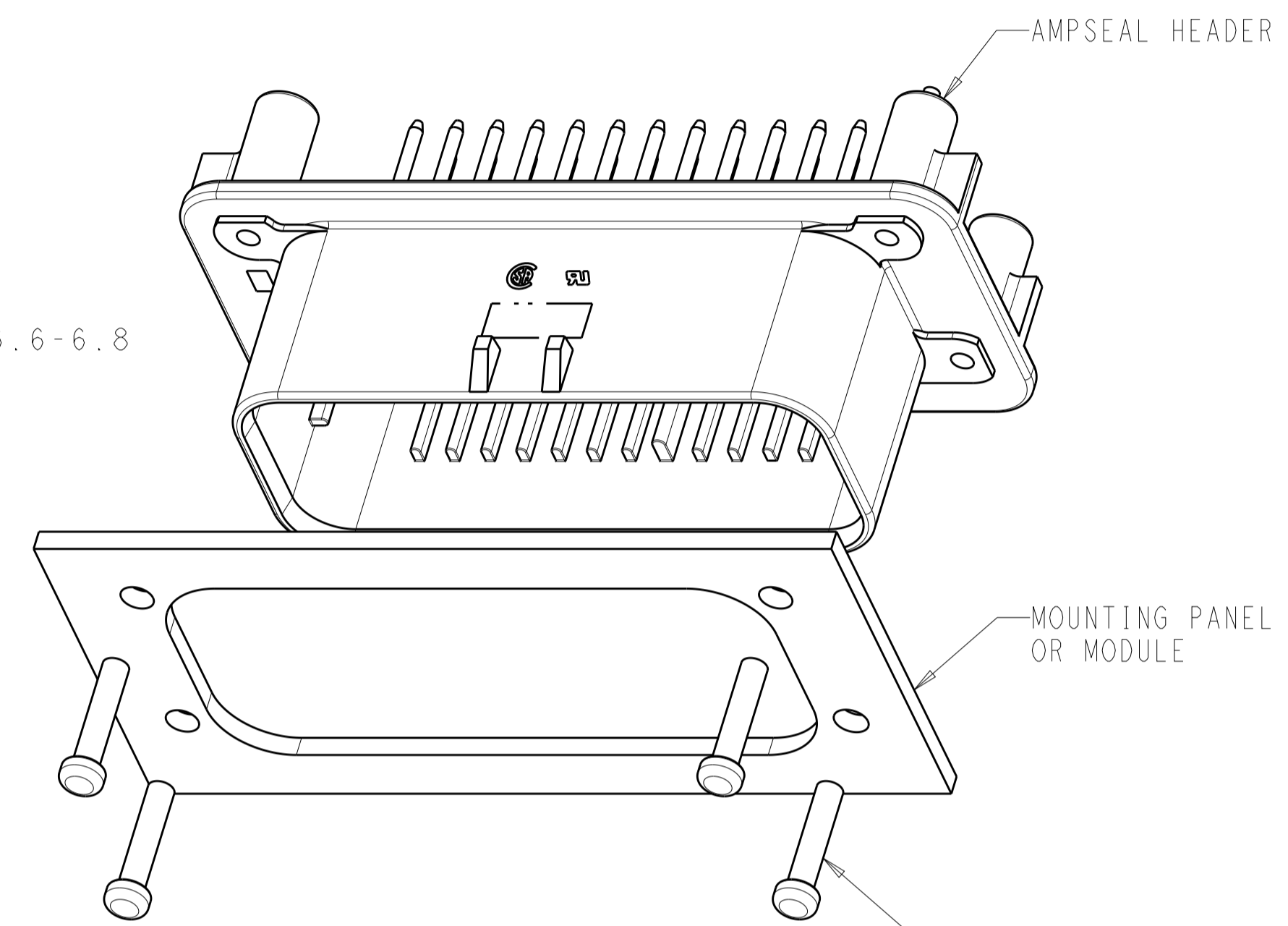

SCALE 2:1

MOUNTING SCREW (4)
 TORQUE TO 0.6N-m TO 0.8N-m

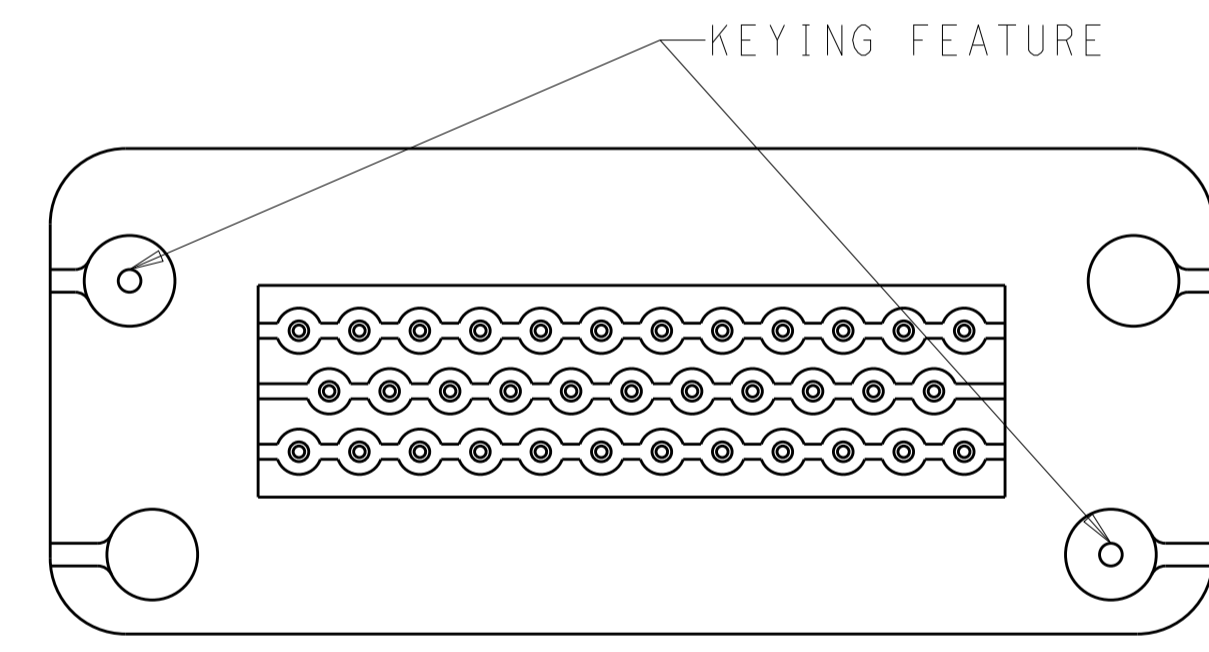

KEYING FOR 776230-1, 1-776230-1, 776230-4,
 1-776230-4 AND 1-776230-6
 SCALE 2:1

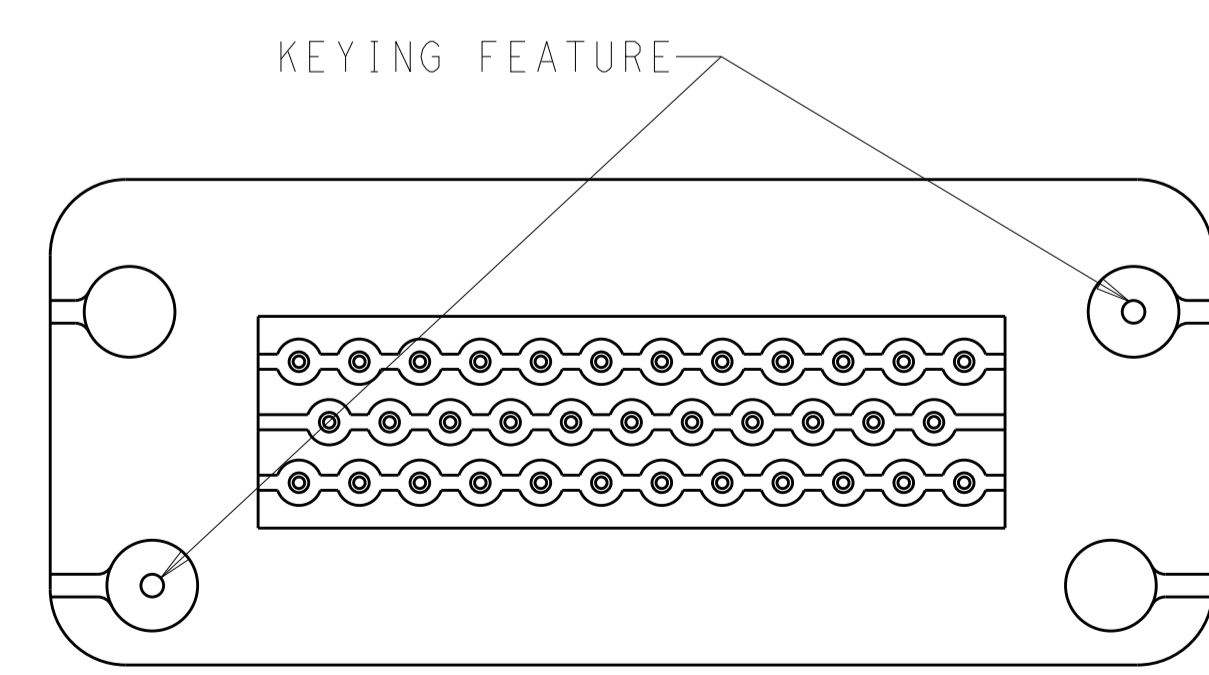

KEYING FOR 776230-2, 1-776230-2, 776230-5
 AND 1-776230-5
 SCALE 2:1

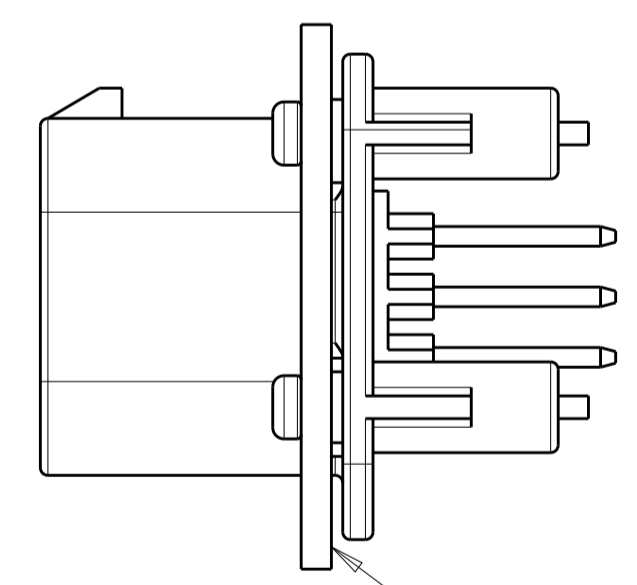

SCALE 2:1

ENSURE THE HEADER IS FLUSH
 TO THE PANEL FACE ALL AROUND
 BEFORE TIGHTENING TO FINAL TORQUE

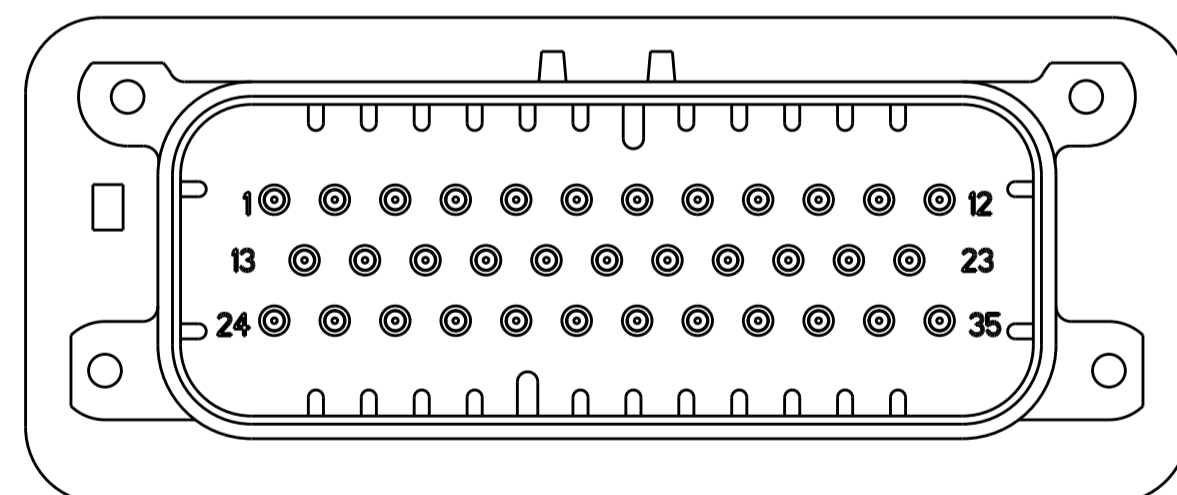

776230-2 & 1-776230-2
 KEY LOCATION
 SCALE 2:1

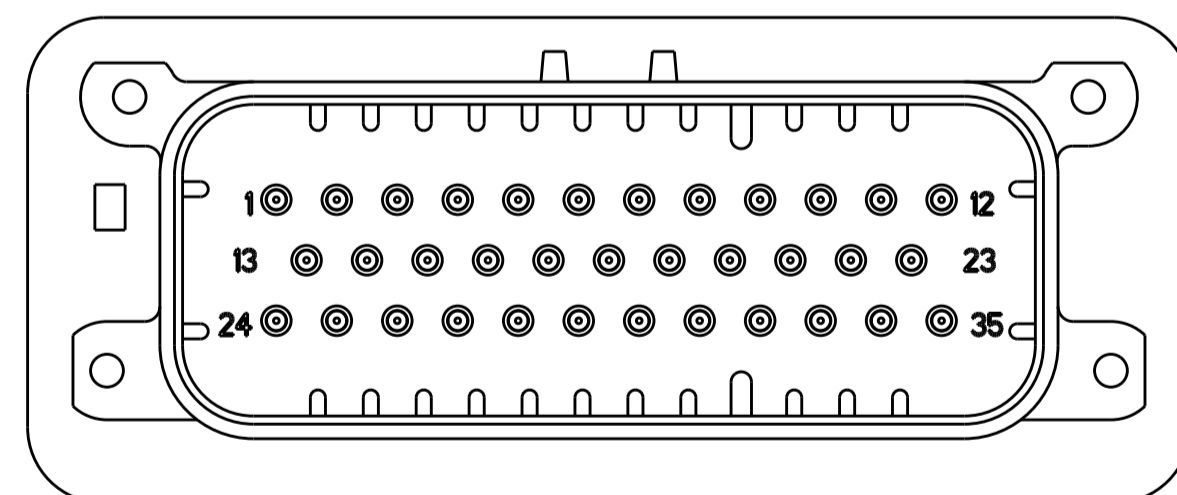

776230-4 & 1-776230-4
 KEY LOCATION
 SCALE 2:1

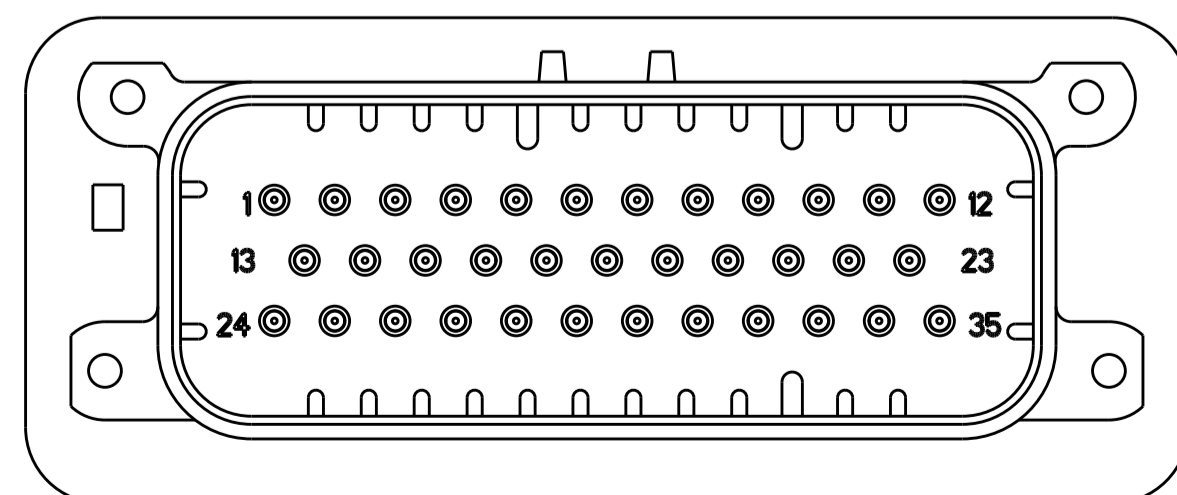

776230-5 & 1-776230-5
 KEY LOCATION
 SCALE 2:1

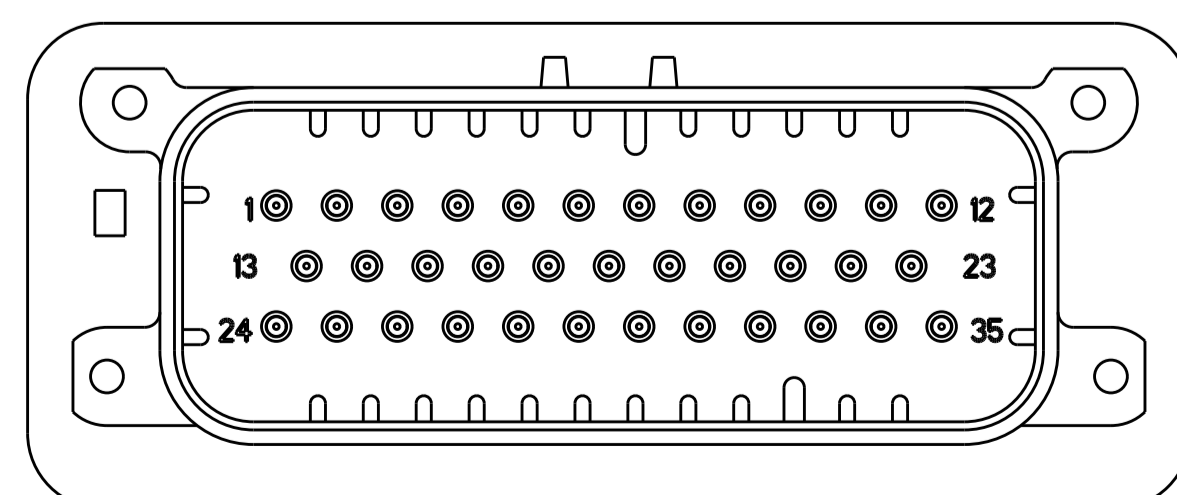

1-776230-6
 KEY LOCATION
 SCALE 2:1

THIS DRAWING IS A CONTROLLED DOCUMENT.		OWN: D. STRAUSSER 04FEB2010	TE Connectivity
DIMENSIONS: mm		CHK: D. STRAUSSER 22MAR2010	
TOLERANCES UNLESS OTHERWISE SPECIFIED:		APVD: D. STRAUSSER 27APR2010	NAME: ASSEMBLY, HEADER, 35 POSITION, VERTICAL, AMPSEAL
0 PLC	±	PRODUCT SPEC	SIZE: CAGE CODE DRAWING NO
1 PLC	±0.2	108-1329	RESTRICTED TO
2 PLC	±0.13	APPLICATION SPEC	A100779C=776230
3 PLC	±	114-16016	SCALE 4:1 SHEET 2 OF 2 REV A9
4 PLC	±	WEIGHT	
ANGLES	±	CUSTOMER DRAWING	